

HighPROTEC-2 | PROTECTION TECHNOLOGY MADE SIMPLE

MRA4-2 | PROTECTION AND CONTROL RELAY FOR FEEDER, GRID AND GENERATOR APPLICATIONS

**NEW
FEATURES**

- DNP 3.0
- Multiple Communication with one device
- ANSI Menu structure
- Page Editor
- New front plate with USB
- IEC61850 with LC interface



APPLICATION

The MRA4 is a high precision and reliable protection and control relay. The intuitive setting concept with plausibility test enables reliable and time optimized configuration of the extensive protection function to a variety of applications such as incoming or outgoing feeder protection, network protection and generator protection. The implemented switchgear management guaranties an efficient and safe control and supervision. The device is a bench mark in flexibility and usability and offers various communication options. The hardware is designed for all nominal values in combination with protection and control functionality. The parameterizing and analyzing software Smart view SE is usable for each HighPROTEC device and free of charge.

COMPREHENSIVE PROTECTION PACKAGE ⁽¹⁾

- Six elements phase overcurrent protection directional and non-directional (ANSI/IEC/51C/51V)
- Four elements earth fault protection ⁽²⁾ non-directional or directional (multi-polarising)
- Two elements unbalanced load protection
- Voltage protection ⁽²⁾ six elements selectable: $V<$, $V>$, $V<(t)$
- Six elements unbalanced voltage supervision
- Flexible Fourth Voltage measuring input ⁽²⁾ 2 elements $VE>$ or VX (for synch-check)
- Synchro-check options Generator-to-System or System-to-System
- Each of the six elements frequency protection can be used as: $f<$, $f>$, ROCOF, vector surge...
- Six elements power protection each can be used as: $P>$, $P<$, Pr , $Q>$, $Q<$, Qr , $S>$, $S<$
- Two elements power factor (PF)

POWER QUALITY

- THD protection

DEMAND MANAGEMENT/ PEAK VALUES

- Peak values of current and power, average current and energy demand

INTERCONNECTION PACKAGE

The comprehensive interconnection package is summarized within one menu:

- Non-discriminating active power direction depending load shedding
- FRT (LVRT): Settable FRT-Profiles, optional AR coordinated
- QV-Protection: Undervoltage-Reactive Power protection
- Automatic Reconnection
- Considerably frequency protection package: Six elements configurable as $f<$, $f>$, df/dt (ROCOF), Vector Surge
- CB-Intertripping
- Synch Check (Generator to mains, mains-to-mains), options e.g. to switch onto dead bus

SLIDING-MEAN-SQUARE SUPERVISION

- Adjustable (VDE-AR 4105)

RECORDERS

- Disturbance recorder: 120 s non volatile
- Fault recorder: 20 faults
- Event recorder: 300 events
- Trend recorder: 4000 non volatile entries

COMMISSIONING SUPPORT

- USB connection
- Customizable Display (Single-Line, ...)
- Customizable Inserts
- Copy and compare parameter sets
- Configuration files are convertible
- Forcing and disarming of output relays
- Fault simulator: current and voltage
- Graphical display of tripping characteristics
- 7 languages selectable within the relay

COMMUNICATION OPTIONS

- IEC61850
- Profibus DP
- Modbus RTU or Modbus TCP
- IEC60870-5-103
- DNP 3.0 (RTU, TCP, UDP)

CONTROL

- 1 breaker
- Breaker wear

LOGIC

- Up to 80 logic equations for protection, control and monitoring

TIME SYNCHRONISATION

- SNTP, IRIG-B00X, Modbus, IEC60870-5-103

PC TOOLS

- Setting and analyzing software Smart view for free
- Including page editor to design own pages

⁽¹⁾ DFT, True RMS or I2 based

⁽²⁾ DFT or True RMS based

FUNCTIONAL OVERVIEW

	Elements	ANSI
Protective Functions		
I, time overcurrent and short circuit protection, all elements can be configured for directional or non-directional supervision. Multiple reset options (instantaneous, definite time, reset characteristics according to IEC and ANSI).	6	50P, 51P, 67P
Voltage controlled overcurrent protection by means of adaptive parameters		51C
Voltage dependent overcurrent protection		51V
Negative phase sequence overcurrent protection		51Q
I _{2>} , unbalanced load protection with evaluation of the negative phase sequence currents	2	46
IB, overload protection with thermal replica and separate pick-up values for alarm and trip functions	1	49
IH ₂ /In, inrush detection with evaluation of the 2nd harmonic	1	Inrush
IG, earth overcurrent and short circuit protection, all elements can be configured for directional (multi-polarising) or non-directional supervision. Tremendous reset options (instantaneous, definite time, reset characteristics according to IEC and ANSI).	4	50N, 51N, 67N
V<, V>, V(t)<, under- and overvoltage protection, time dependent undervoltage protection	6	27, 59
Voltage asymmetry supervision (V012)		
V1, under and overvoltage in positive phase sequence system	6	47
V2, overvoltage in negative phase sequence system		
Each of the six frequency protection elements can be used as: f< fs, df, dt, ROCOF, DF/DT, vector surge, ...	6	81U/O, 81R, 78
VX, residual voltage protection or bus bar voltage for Synch Check	2	59N
AR, automatic reclosing	1	79
ExP, External alarm and trip functions	4	
PQS, Power protection	6	32, 37
PF, Power factor	2	55
FRT (optional coordination with AR-feature)	27 (t)	27 (t, AR)
Q(V) Protection (undervolt. dep. directional reactive power protection with reclosing disengaging)		
UFLS (non-discriminating active power direction depending load shedding)		
10-Minutes-Mean-Square-Sliding Supervision: adjustable according to VDE-AR 4105		
Synch Check		25
Control and Logic		
Control: Position indication, supervision time management and interlockings for 1 breaker		
Logic: Up to 80 logic equations, each with 4 inputs, selectable logical gates, timers and memory function		
Supervision Functions		
CBF, circuit breaker failure protection	1	50BF
TCS, trip circuit supervision	1	74TC
LOP, loss of potential	1	60FL
FF, fuse failure protection via digital input	1	60FL
CTS, current transformer supervision	1	60L
CLPU, cold load pickup	1	
SOTF, switch onto fault	1	
Demand management and peak value supervision (current and power)		
THD supervision		
Breaker wear with programmable wear curves		
Recorders: Disturbance recorder, fault recorder, event recorder, trend recorder		

FUNCTIONAL OVERVIEW IN ANSI FORM

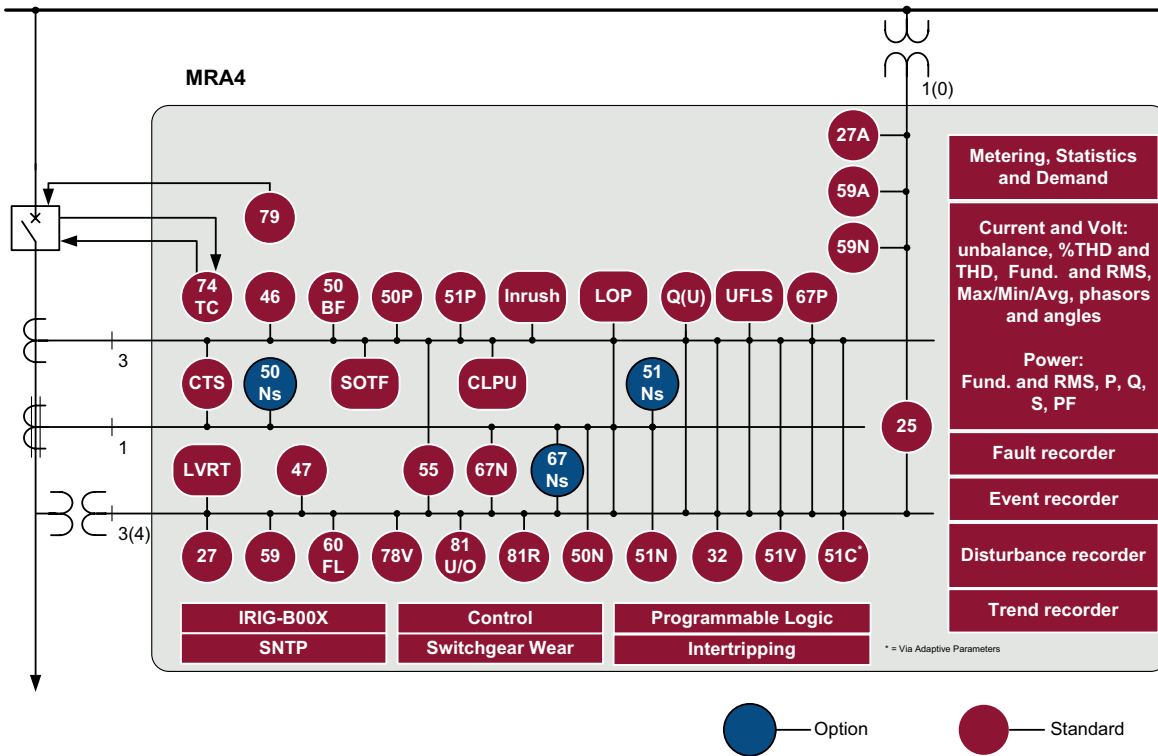

APPROVALS

CONNECTIONS (EXAMPLE)



certified regarding UL508
(Industrial Controls)



certified regarding
CSA-C22.2 No. 14
(Industrial Controls)



certified by EAC
(Eurasian Conformity)



Type tested (and certified)
regarding IEC60255-1



certified regarding "BDEW-Richtlinie für
Erzeugungsanlagen am Mittel-
spannungsnetz, Ausgabe Juni 2008"
(German grid code standard)

complies with IEEE 1547-2003
amended by IEEE 1547a-2014

complies with ANSI C37.90-2005

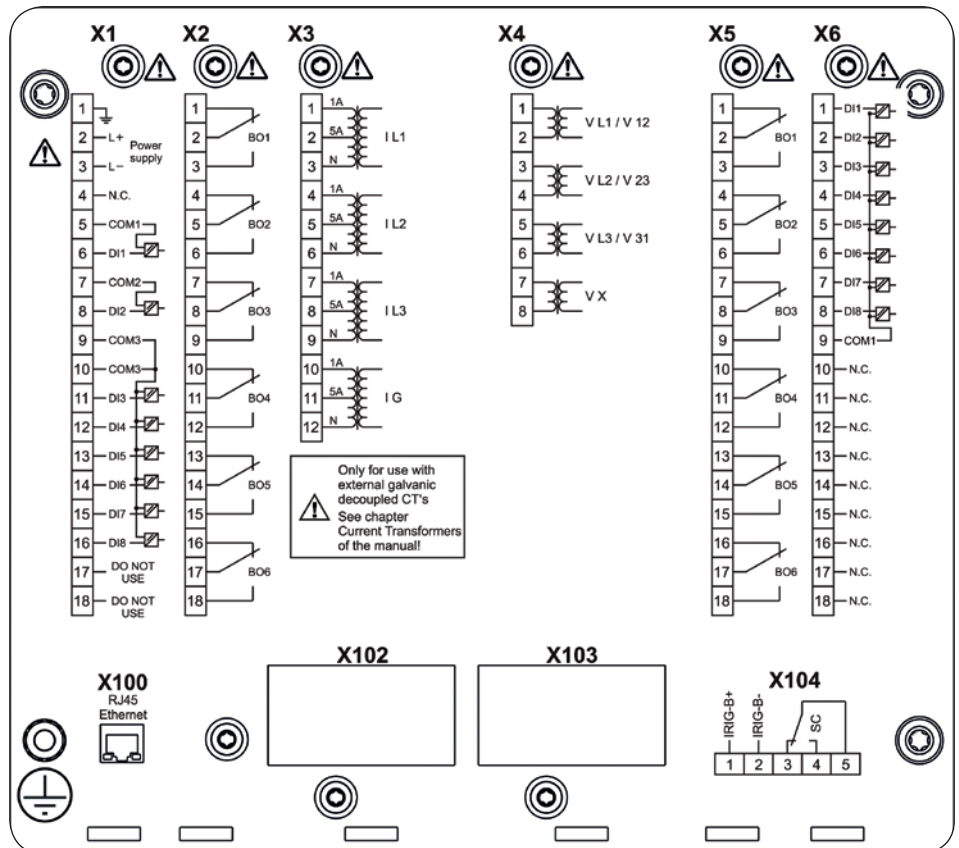

ORDER FORM MRA4-2

Directional Feeder Protection				MRA4	-2				
Version 2 with USB, enhanced communication and user options									
Digital Inputs	Binary output relays	Housing	Large display						
8	7	B2	-					A	
16	13	B2	-					D	
Hardware variant 2									
Phase Current 5 A/1 A, Ground Current 5 A/1 A									0
Phase Current 5 A/1 A, Sensitive Ground Current 5 A/1 A									1
Housing and mounting									
Door mounting									A
Door mounting 19" (flush mounting)									B
Communication protocol									
Without protocol									A
Modbus RTU, IEC60870-5-103, DNP3.0 RTU <i>RS485/terminals</i>									B*
Modbus TCP, DNP3.0 TCP/UDP <i>Ethernet 100 MB/RJ45</i>									C*
Profibus-DP <i>optic fiber/ST-connector</i>									D*
Profibus-DP <i>RS485/D-SUB</i>									E*
Modbus RTU, IEC60870-5-103, DNP3.0 RTU <i>optic fiber/ST-connector</i>									F*
Modbus RTU, IEC60870-5-103, DNP3.0 RTU <i>RS485/D-SUB</i>									G*
IEC61850, Modbus TCP, DNP3.0 TCP/UDP <i>Ethernet 100MB/RJ45</i>									H*
IEC60870-5-103, Modbus RTU, DNP3.0 RTU <i>RS485/terminals</i>									I*
Modbus TCP, DNP3.0 TCP/UDP <i>Ethernet 100 MB/RJ45</i>									J*
IEC61850, Modbus TCP, DNP3.0 TCP/UDP <i>Optical Ethernet 100MB/LC duplex connector</i>									K*
Modbus TCP, DNP3.0 TCP/UDP <i>Optical Ethernet 100MB/LC duplex connector</i>									L*
Harsh Environment Option									
None									A
Conformal Coating									B
Available menu languages (in every device)									
Standard English/German/Spanish/Russian/Polish/Portuguese/French									

* Within every communication option only one communication protocol is usable.
Smart view can be used in parallel via the Ethernet interface (RJ45).

The parameterizing- and disturbance analyzing software Smart view is included in the delivery of HighPROTEC devices.

Current inputs	4 (1 A and 5 A) with automatic CT Disconnect
Voltage inputs	4 (0–800 V)
Digital Inputs	Switching thresholds adjustable via software
Power supply	Wide range power supply 24 V _{DC} - 270 V _{DC} / 48 V _{AC} - 230 V _{AC} (-20/+10%)
Terminals	All terminals plug type
Type of enclosure	IP54
Dimensions of housing (W x H x D)	19" flush mounting: 212.7 mm x 173 mm x 208 mm 8.374 in. x 6.811 in. x 8.189 in. Door mounting: 212.7 mm x 183 mm x 208 mm 8.374 in. x 7.205 in. x 8.189 in.
Weight (max. components)	approx. 4.7 kg / 10.36 lb

CONTACT:

North & Central America

Phone: +1 970 962 7331
E-mail: SalesPGD_NAandCA@woodward.com

South America

Phone: +55 19 3708 4800
E-mail: SalesPGD_SA@woodward.com

Europe

Phone: +49 2152 145 331
E-mail: SalesPGD_EUROPE@woodward.com

Middle East & Africa

Phone: +971 2 6275185
E-mail: SalesPGD_MEA@woodward.com

Russia

Phone: +7 812 319 3007
E-mail: SalesPGD_RUSSIA@woodward.com

China

Phone: +86 512 8818 5515
E-mail: SalesPGD_CHINA@woodward.com

India

Phone: +91 124 4399 500
E-mail: SalesPGD_INDIA@woodward.com

ASEAN & Oceania

Phone: +49 711 78954 510
E-mail: SalesPGD_ASEAN@woodward.com

For more information please contact: